

1-2: Board is internally powered (by Jetson),
VCC_TARGET provides board voltage to debugger.
2-3: Board is powered by debugger.

This is RXD/TXD from the
perspective of the debugger.

Grounding ADR sets
I2C addr to 0x76
Connecting CS to VDDIO
at power-up
enables I2C interface.

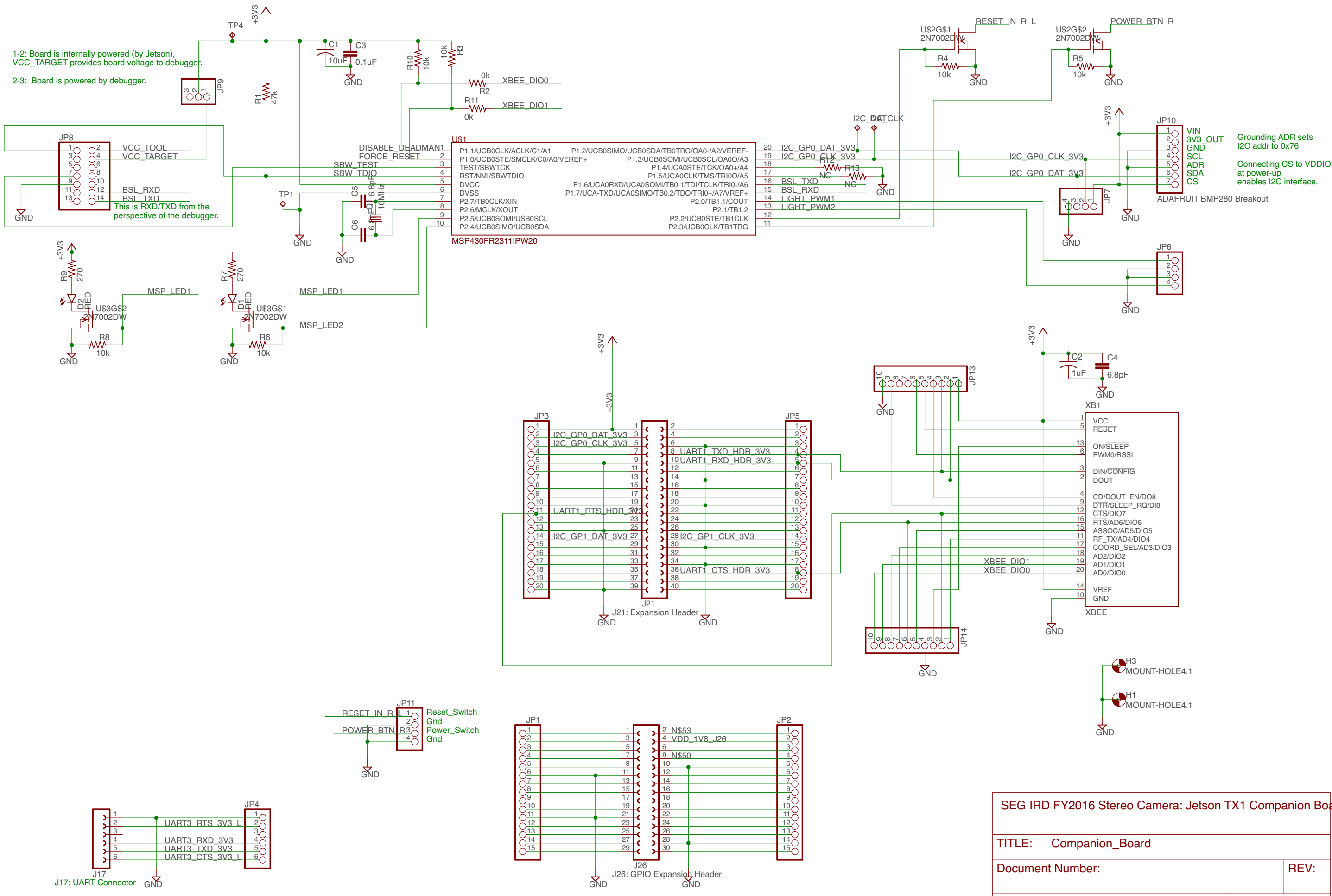

SEG IRD FY2016 Stereo Camera: Jetson TX1 Companion Board

TITLE: Companion_Board

Document Number: REV:

Date: 10/26/16 3:35 PM Sheet: 1/1