

Dementia

Posted 11-4-04

Key Points

Genetics

- Early-onset Alzheimer disease (AD) refers to the onset of dementia prior to age 65 years, and often before age 55 years; when it is familial, inheritance is autosomal dominant.
- Mutations in the *PSEN1*, *PSEN2*, and *APP* genes cause autosomal dominant early-onset AD. Genetic testing of affected individuals may identify the disease-causing mutation. If a disease-causing mutation is identified, predictive testing can be offered to other family members, to determine whether they have inherited the mutation.

Ethics

- A mutation in one of the genes associated with early-onset AD confers a nearly 100% chance of developing AD, but no treatment is available to prevent the disease or diminish its severity. As a result, the choice to undergo predictive testing is a matter of personal choice and has significant social implications. Careful attention must be given to pre-test counseling and informed consent.

Learning Objectives

Participants will be able to:

- Recognize the family history characteristics of autosomal dominant inheritance of early-onset familial Alzheimer disease;
- Describe the counseling issues for family members considering genetic testing.

Family History Issues

Because early-onset familial Alzheimer disease (AD) is inherited in an autosomal dominant manner, most affected individuals have an affected parent who had this condition.

Red Flags



Onset of dementia prior to age 65, and especially prior to age 55, increases the likelihood of autosomal dominant inheritance.

Case 15. Cognitive Difficulties in a 45-Year-Old Man

Mr. Y comes to clinic with his wife to discuss an upsetting experience that occurred a week ago. Mr. Y is a 45-year-old computer engineer who manages a software development unit at a large company. He is well known within the industry as the developer of key components of several widely used programs. He had been under a great deal of stress at work, so he and his wife decided to take a vacation. They went to San Francisco to visit friends and attend the opera. On the first day of their trip, their 22-year-old daughter, Sue, who was at home, received a call from Mr. Y. He was in a telephone booth in Union Square. He could not remember the name of the hotel at which he and his wife were staying; he didn't know what to do. Sue gave him the name of the hotel and talked him through getting a taxi back to the hotel. Shaken, he and his wife returned home.

He denies drug use of any kind, drinks moderately, and recently underwent routine medical testing as part of an annual physical examination, with all results normal. He jogs 30 minutes a day.

Physical examination is unremarkable. There are no focal neurological signs. He is unable to remember three objects. He knows his name and telephone number but has trouble with his birthday, his address, and the name of the President of the U.S. Asked to describe the details of what happened in San Francisco, he says, "The same thing happened to my mother." Prompted, he tells a story that is difficult to follow, about his mother getting lost. Mrs. Y explains that Mr. Y's mother, age 65 years, has been in a nursing home for the past five years, with a diagnosis of Alzheimer disease. She also notes that Mr. Y has been under considerable pressure at work, with his boss finding his performance unsatisfactory.

Clinical Care Issues

Mr. Y requires a workup for neurological and systemic illness, with attention to treatable causes of his recent onset of cognitive difficulties, particularly given his age and previous good health. However, his family history raises the possibility of an inherited early-onset familial AD. **Approximately 2% of AD is attributed to autosomal dominant early-onset familial AD.** The majority of these cases are due to mutations in the *PSEN1* (AD3) gene; mutations in two other genes, *APP* (AD1) and *PSEN2* (AD4), have also been implicated (see [Table 1](#); [GeneReviews: Alzheimer Disease Overview, Early-Onset Familial Alzheimer Disease](#)). Mutations in all three genes result in similar clinical findings: age of onset of early-onset familial AD is prior to 65 years, and often prior to 55 years. The early-onset dementias caused by these mutations (designated as AD1, AD3, and AD4) are all distinguishable from late-onset AD (AD2), the common form of Alzheimer disease, which typically occurs after age 65, and is influenced by both genetic and environmental risk factors. One genetic risk factor for late-onset AD, *ApoEε4*, has been well characterized (see [Case 14](#)).

Risk Assessment

A three-generation family history would be helpful in determining the likelihood of autosomal dominant early-onset AD in Mr. Y's family. Mr. Y's pedigree is shown below. (The arrow indicates the patient.)

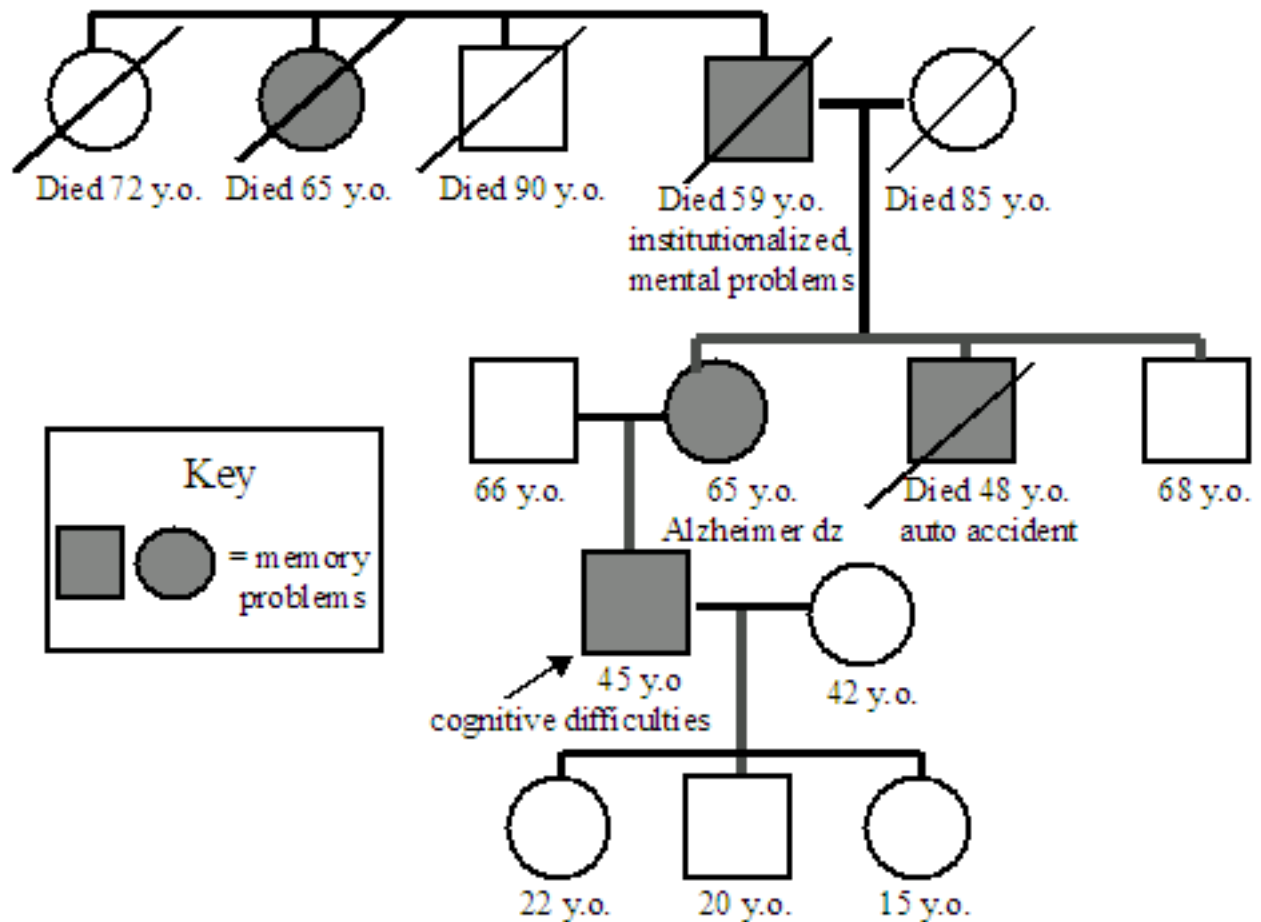

This family history reveals that Mr. Y's mother was diagnosed with AD at age 60 years, after at least ten years of progressive memory problems. In addition, one of Mr. Y's two maternal uncles was noted to have memory problems before he died in an automobile accident at age 48 years. Mr. Y's maternal grandfather was institutionalized at age 52 years and died at age 59 years; he was said to have "severe mental problems." This grandfather had a sister with "memory problems" who died at 65 years, another sister who died at 72 years without evidence of memory problems, and a brother who remained healthy and alert until age 90 years.

This family history is consistent with autosomal dominant inheritance of early-onset AD in several respects:

- Disease occurs in successive generations.
- Both males and females are affected.
- In each generation, approximately equal numbers of individuals are affected and unaffected.

Mr. Y in fact has early-onset AD. His diagnosis and his family history are consistent with autosomal dominant AD.

Genetic Counseling and Testing

Mr. and Mrs. Y have three children, aged 22, 20, and 15, each of whom has a 50% chance of inheriting the condition. Genetic counseling would allow the family to learn more about autosomal dominant inheritance and about options for genetic testing. Genetic counseling would also allow them to better understand the psychosocial issues associated with genetic testing for this condition (see [Ethical/ legal/ social/ cultural issues](#), below) as well as the technical aspects of such testing.

Genetic testing is available for mutations in the *PSEN1* gene, and on a limited basis for the *PSEN2* and *APP* genes (see [Table 1](#)). These mutations have nearly 100% penetrance; that is, almost all people with a mutation develop early-onset dementia. The age of onset is usually in the 40s or early 50s although onset as early as the 30s and as late as the early 60s occurs. Onset after age 65 is thought to be very rare, with penetrance essentially complete by that age. There are likely other genes causing early-onset familial Alzheimer disease since some families displaying autosomal dominant inheritance have no identifiable mutation in these genes.

If Mr. Y has genetic testing and is found to have an identifiable mutation in one of the genes causing early-onset AD, genetic counseling and testing could be offered to his adult children to determine whether they have inherited the disease-causing mutation. However, genetic testing is not useful in predicting specific age of onset, severity, type of symptoms, or rate of progression in asymptomatic individuals (see [GeneReviews](#)). The option of genetic testing may or may not be of interest to different family members, and discussion of the implications of testing may raise difficult issues for the family (see [Ethical / legal / social / cultural issues](#), below). **In addition to evaluating the patient to confirm the diagnosis of AD, the primary care provider can play a role in assuring that family members' needs for information, counseling, and emotional support are addressed over time.**

Table 1. Genes Causing Early-Onset Familial Alzheimer Disease

Subtype	Gene Symbol	Percent of All Early-Onset Familial AD	Name of Protein

AD3	<i>PSEN 1</i>	30-70%	Presenilin 1
AD4	<i>PSEN 2</i>	<5%	Presenilin 2
AD1	<i>APP</i>	10-15%	Amyloid beta A4 protein
Other	Unknown	10-50%	Unknown

Interventions

The mainstay of management for AD is supportive care. Each symptom is managed on an individual basis [Clare et al 2002]. In general, affected individuals eventually require assisted living arrangements or care in a nursing home. In many areas, courses and support groups are available for family members and caregivers.

The exact biochemical basis of Alzheimer disease is not known. The cholinergic system and other neurotransmitters are deficient. Agents that increase cholinergic activity, such as donepezil and rivastigmine, may play some role in treatment, but only a minority of patients show even a modest benefit. The magnitude of benefit may be greater in clinical trials than in practice.

Nonsteroidal anti-inflammatory drugs (NSAIDs), lipid-lowering agents, ginkgo, vitamin E, and estrogen are also being investigated as possible therapeutic agents. None of these pharmacologic treatments has been systematically evaluated in patients with early-onset Alzheimer disease.

Ethical/Legal/Social/Cultural Issues

Predictive testing for early-onset familial Alzheimer disease

Mr. Y's three children may be interested in having predictive genetic testing for early-onset Alzheimer disease for various reasons, including family planning, financial matters, and career planning. Alternatively, they may simply "need to know." Since no methods are known to delay or stop disease progression for at-risk individuals, the only benefit to testing is the knowledge of one's genetic status. Since knowing that the presence of a mutation in one of the genes causing early-onset AD confers a 100% chance of developing AD, having predictive testing is a personal decision that ideally is made only after significant reflection.

Predictive testing protocols in medical genetics clinics include formal pre-test counseling in which the motives for requesting the test, the individual's knowledge of the disease, the possible impact of positive and negative test results, and mental status are assessed. Pre-test counseling should also include discussion of possible problems that may be encountered with regard to health, life, and disability insurance coverage, employment and educational discrimination, and changes in social and family interaction. Another issue to consider is the implications of revealing the genetic status of other at-risk family members. Procedures should be followed to safeguard confidentiality of test results and to ensure arrangements for long-term follow-up and evaluation.

Of note, one of Mr. and Mrs. Y's children is only 15 years old. **Genetic testing for adult-onset conditions for which no treatment is available is typically deferred until the age of majority at a minimum** since testing during childhood violates the right of the child to make his or her own informed choice as an adult, opens the possibility of stigmatization within the family and in other social settings, and may have serious educational and career implications.

Resources

- **Alzheimer's Association National Headquarters**
919 North Michigan Avenue, Suite 1000
Chicago, IL 60611-1676
Phone: 800-272-3900; 312-335-8700
Fax: 312-335-1110
Email: info @alz.org
- **Alzheimer's Education and Referral Center**
PO Box 8250
Silver Springs, MD 20907-8250
Phone: 800-438-4380
Email: adear@alzheimers.org
- **National Institute on Aging**
Building 31, Room 5C27
31 Center Drive, MSC 2292

Bethesda, MD 20892

Phone: 301-496-1752

- **National Library of Medicine Genetics Home Reference: Alzheimer Disease**
- **NCBI Genes and Disease Webpage: Alzheimer Disease**
- **Dementia.com**
- **GeneTests: Online Medical Genetics Information Resource**
- **GeneTests Resources for Early-Onset Familial Alzheimer Disease** 

References

Campion D, Dumanchin C, Hannequin D, Dubois B, Belliard S, Puel M, Thomas-Anterion C, Michon A, Martin C, Charbonnier F, Raux G, Camuzat A, Penet C, Mesnage V, Martinez M, Clerget-Darpoux F, Brice A, Frebourg T (1999) Early-onset autosomal dominant Alzheimer disease: prevalence, genetic heterogeneity, and mutation spectrum. *Am J Hum Genet* 65:664-70 [[Medline](#)]

Campion D, Flaman JM, Brice A, Hannequin D, Dubois B, Martin C, Moreau V, Charbonnier F, Didierjean O, Tardieu S, et al (1995) Mutations of the presenilin I gene in families with early-onset Alzheimer's disease. *Hum Mol Genet* 4:2373-7 [[Medline](#)]

Clare L (2002) We'll fight it as long as we can: coping with the onset of Alzheimer's disease. *Aging Ment Health* 6:139-48 [[Medline](#)]

Cruts M, van Duijn CM, Backhovens H, Van den Broeck M, Wehnert A, Serneels S, Sherrington R, Hutton M, Hardy J, St George-Hyslop PH, Hofman A, Van Broeckhoven C (1998) Estimation of the genetic contribution of presenilin-1 and -2 mutations in a population-based study of presenile Alzheimer disease. *Hum Mol Genet* 7:43-51 [[Medline](#)]

Hudson KL, Rothenberg KH, Andrews LB, Kahn MJE, Collins FS (1995) Genetic discrimination and health insurance: an urgent need for reform. *Science* 270:391-3 [[Medline](#)]

Janssen JC, Beck JA, Campbell TA, Dickinson A, Fox NC, Harvey RJ, Houlden H, Rossor MN, Collinge J (2003) Early-onset familial Alzheimer's disease: Mutation frequency in 31 families. *Neurology* 60:235-9 [[Medline](#)]

McConnell LM, Koenig BA, Greely HT, Raffin TA (1999) Genetic testing and Alzheimer disease: recommendations of the Stanford Program in Genomics, Ethics, and Society. *Genet Testing* 3: 3-12 [[Medline](#)]

Post SG, Whitehouse PJ, Binstock RH, Bird TD, Eckert SK, Farrer LA, Fleck LM, Gaines AD, Juengst ET, Karlinsky H, Miles S, Murray TH, Quaid KA, Relkin NR, Roses AD, St George-Hyslop PH, Sachs GA, Steinbock B, Truschke EF, Zinn AB (1997) The clinical introduction of genetic testing for Alzheimer disease: an ethical perspective. *JAMA* 277:832-6 [[Medline](#)]